



Cutting to size Instructions

Note:
For trimming more than 1”

To cut regular retractable screens. For cut downs, got o next section

Work with round pin end

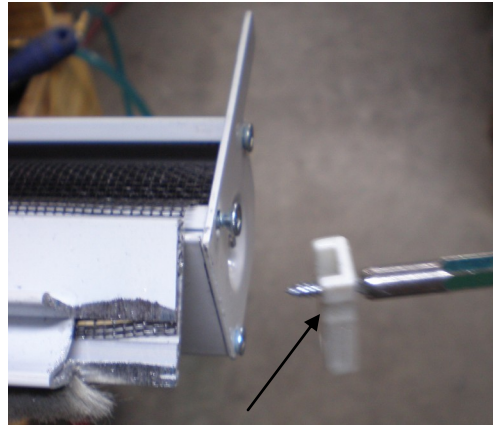
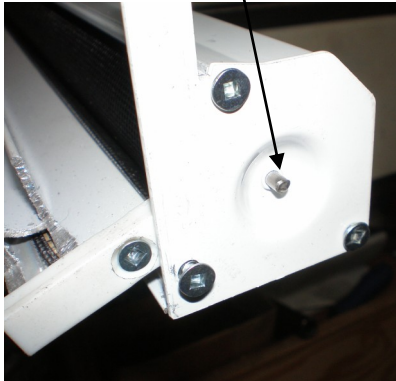

Remove track guide.

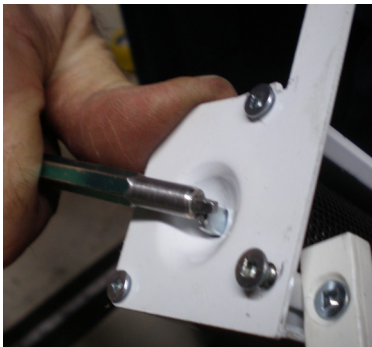

On opposite end,
push square pin in,
and...

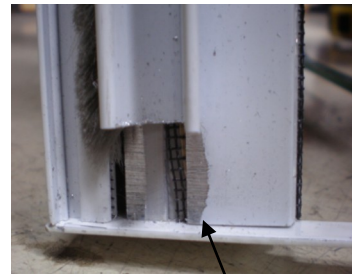
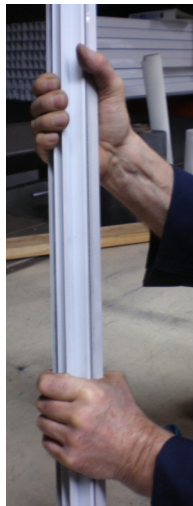

With a firm gripe and housing at a slight an-
gle, tap the round pin end on a solid surface so
that everything becomes flush.

Manufactured by Stollco Industries Ltd. Port Coquitlam, BC 604.941.6291
www.stollco.com

Cutting to size Instructions

Mark housing to length less 3/16" allowance.
(See measuring chart)

Page 2

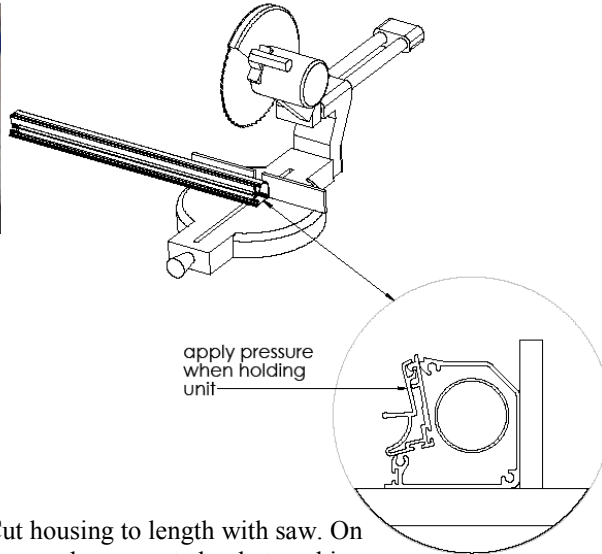

Cut housing to length with saw. On powered saws cut slowly to achieve a better finish.

Loosen screw and remove pin postioner.

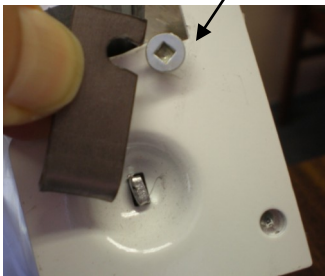

Push tube and screen in so that square pin is more exposed and remains in its position



De-burr inside of tube.

IF cutting an existing retractable screen, otherwise remove and save screws, then go to next section

Remove end cap



Knock out tube end cap using a pipe

Cutting to size Instructions

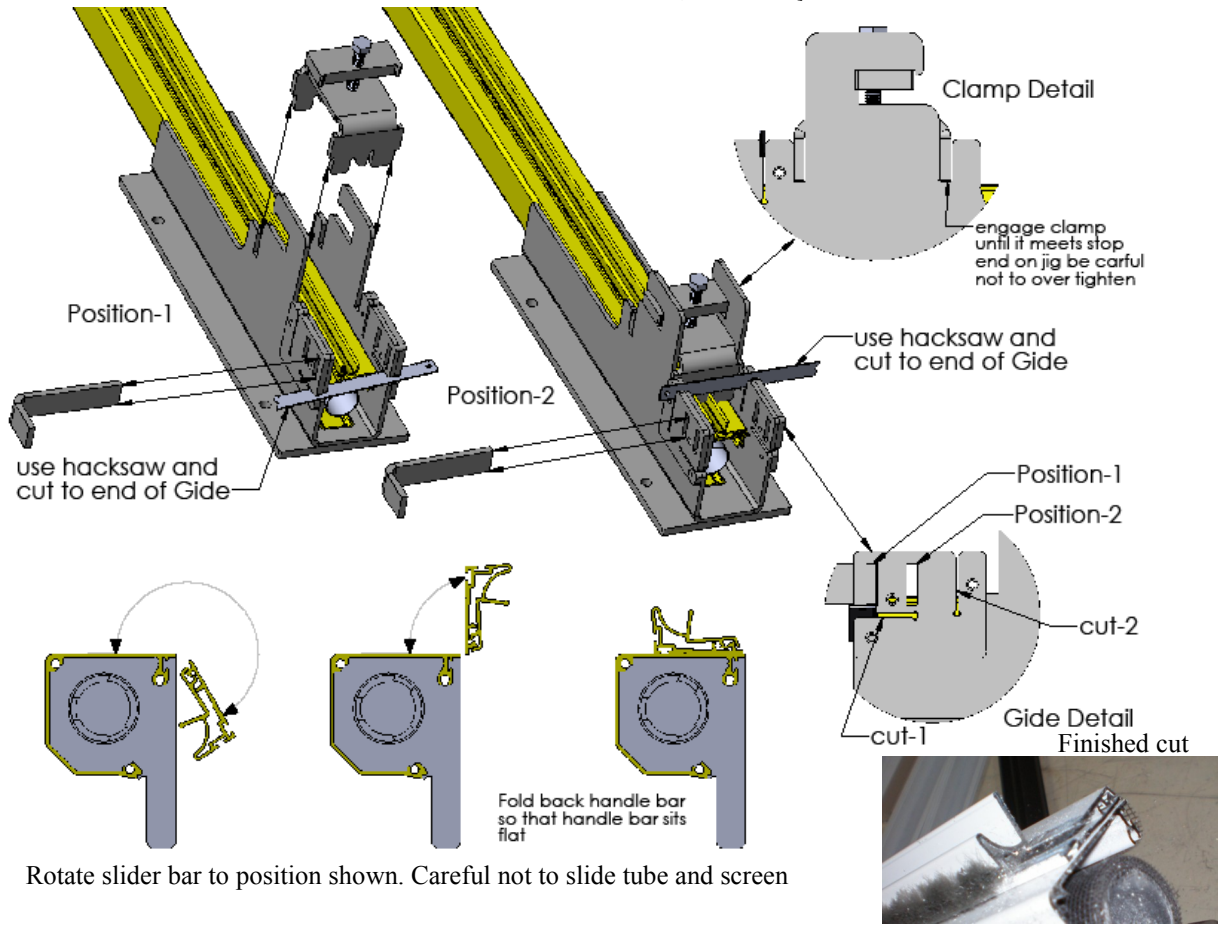

Insert tube end cap and tap into position.

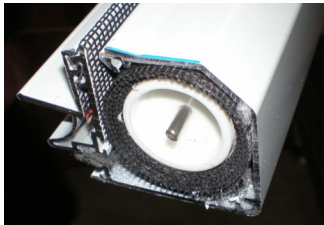

Replace cap and secure.



Place provided housing end cap on. secure with two screws.

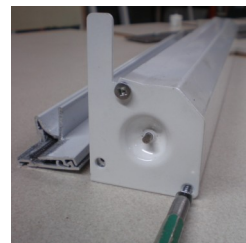

Cutting to size Instructions

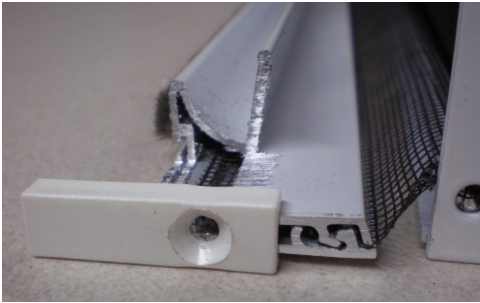

Put slider on end of handle bar, slide into position and attach with (#5 1/2" Screw)

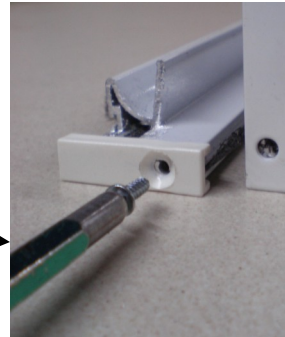

Trim tracks to length. Slide into position with groove lining up to end bracket blade. Attach securely with #6 x 5/8" screw.

